

(No Model.)

2 Sheets—Sheet 1.

F. W. CLOUGH.
Gage Lathes.

No. 234,536.

Patented Nov. 16, 1880.

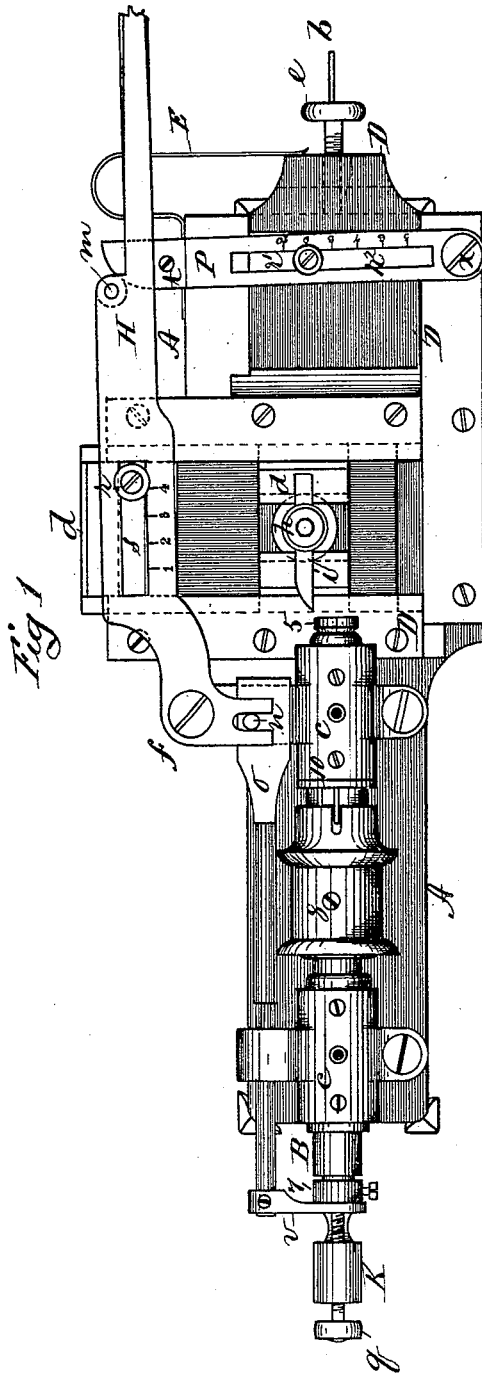

Witnesses
Wm H Chapin
Chas Bill

Inventor
Francis W Clough
By Henry A Chapin
Atty

(No Model.)

2 Sheets—Sheet 2.

F. W. CLOUGH.
Gage Lathes.

No. 234,536.

Patented Nov. 16, 1880.

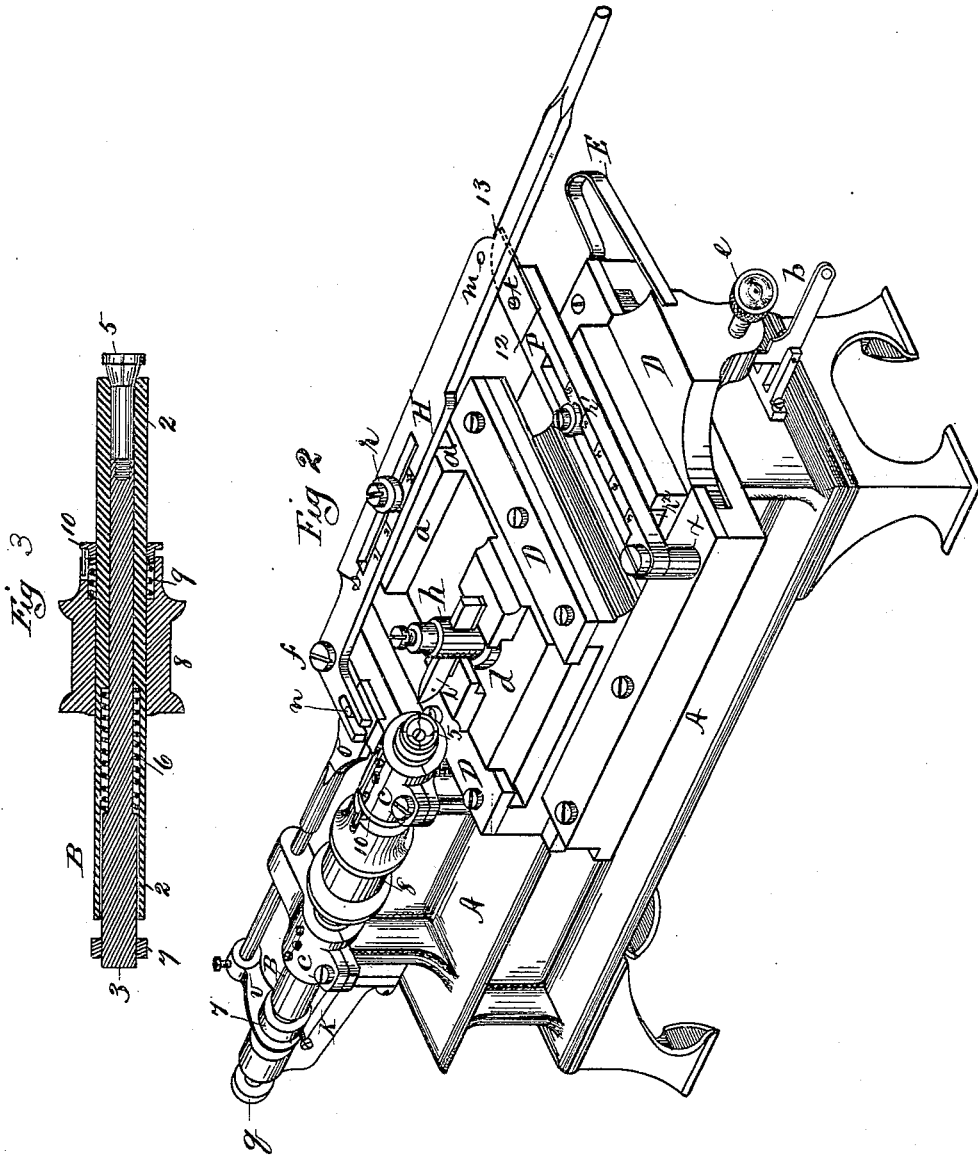

Witnesses
Wm. H. Chapin.
Chas. Bill

Inventor
Francis W. Clough.
By Henry A. Chapin
Att'y

UNITED STATES PATENT OFFICE.

FRANCIS W. CLOUGH, OF SPRINGFIELD, MASSACHUSETTS, ASSIGNOR OF ONE-HALF TO NELSON C. NEWELL, OF SAME PLACE, AND JOHN C. DICKINSON, OF NEW YORK, N. Y.

GAGE-LATHE.

SPECIFICATION forming part of Letters Patent No. 234,536, dated November 16, 1880.

Application filed April 29, 1880. (No model.)

To all whom it may concern:

Be it known that I, FRANCIS W. CLOUGH, a citizen of the United States, residing at Springfield, in the county of Hampden and State of Massachusetts, have invented new and useful Improvements in Gage-Lathes, of which the following is a specification.

My invention relates to that class of lathes which are provided with devices for causing the turning-tool to be guided automatically, so that it may cut the object revolved by the lathe-spindle to a certain form; and the objects of my invention are to provide improved tool-guiding mechanism, by the aid of which the motions of said tool relative to the article to be turned may be adjusted to cut automatically various irregular forms, guided so to do otherwise than solely by a special form for each article of differing contour, and to provide an improved clamping-spindle for such lathes.

I attain the above-named objects by the construction and devices illustrated in the accompanying drawings, in which—

Figure 1 is a plan view of my machine. Fig. 2 is an isometrical view of the same, and Fig. 3 is a longitudinal section of the clamping-spindle with the driving-pulley thereon.

Like letters refer to like parts in the several figures.

Upon the bed A of my machine I arrange, in the usual manner, the spindle-bearings *c*. The upper side of said bed, in front of the work-holding end of the spindle B, is provided with suitable ways, as shown, in which the carriage D may slide longitudinally thereon.

Through a down-hanging portion of carriage D is placed an adjusting-screw, *e*, adapted to have its inner end bear against the end of bed A. A spring, E, is attached to the bed, and the free end of it is caused to bear against the end of carriage D to push it toward the end of spindle B.

Pivoted to a support on the end of bed A, as shown, is an elbow-lever, *b*, the short arm of which engages with carriage D, and its long arm is pierced with a hole, as shown, whereby said lever may, by any suitable hook or other device, be connected to a foot-treadle.

The upper side of carriage D has formed upon it transversely suitable ways, as shown, adapted to the reception therein of the tool-post carriage *d*, which is arranged to have a transverse motion in said ways, and is provided also with a transverse groove, *r*², into which the lower end of pin *r*' projects. A rib, *a*, on the top side of carriage *d* has a groove cut therein, as shown.

A tool-post, *h*, supporting the cutting-tool *i*, is secured on the face of carriage *d*, in the usual manner.

An elbow-lever, H, is pivoted at *f* on bed A, and the short arm thereof is slotted, as shown, and engages with a pin, *n*, in the flat end of a rod, *o*. Said lever H has also a slot, *s*, in it, having graduation-marks along one edge of it, as shown.

A pin, *r*, is secured adjustably in slot *s* in lever H, the lower end of which projects into the aforesaid slot in rib *a* on carriage *d* under said lever, and a downwardly-projecting pin, *m*, is secured in said lever between pin *r* and the end thereof.

A lever, P, having in it a slot, as shown, is pivoted to bed A at *x*, and the said slot in this lever has also a series of graduation-marks formed along one edge thereof, as shown, and a pin, *r*', is secured adjustably in this lever, similar to pin *r* in lever H. The free end of lever P is adapted to have a form-plate, *t*, secured thereto, against the edge of which pin *m* in lever H operates when the latter is swung toward the operator.

Attached to the rear end of bed A, as shown, is a support, K, which supports a spindle-bearing screw, *g*, adapted to bear against the rear end of spindle B. A sliding rod, *o*, lying parallel to spindle B, is supported in proper bearings on bed A, as shown, a pin, *n*, in which engages with lever H, as heretofore explained. Secured to the rear end of rod *o* by a set-screw, as shown, is an arm, *v*, having in it, near the end, a perforation to allow the rear end of spindle B to pass through it.

Spindle B consists of the outer tubular casing, 2, having a passage drilled quite through it, as seen in Fig. 3, and counterbored to a larger size from its rear end inward nearly half

the length of it, as shown, and of an inner clamp-rod, 3, turned to fit and slide freely in the casing 2, its diameter being adapted to the two sizes of holes in the latter. The clamp-rod 3 has its rear end turned of the diameter of the counterbored portion of casing B; but said larger rear end, as seen in Fig. 3, does not reach to the shoulder at the bottom of the said counterbore, thus forming an annular chamber between the smaller part of said clamp-rod and said casing, at one end of which is a shoulder on the latter, and at the opposite end of which is a shoulder on the clamp-rod, as shown. The forward end of clamp-rod 3 is tapped out to allow of screwing the slotted spring-clamp 5 into the end of it. Said spring-clamp is of exterior conical form for a short distance back of its outer end, is sawed longitudinally, as shown, and has its projecting end turned out to allow of placing articles of a disk form therein, as seen in Fig. 2.

A spiral spring, 6, is placed over clamp-rod 3. The latter is placed in casing 2, compressing spring 6 between the said shoulders at the ends of said annular chamber, and the spring-clamp 5 is screwed into rod 3, in the position seen in Fig. 3, and spring 6 thus draws the conical end of the spring-clamp against the open end of casing B, causing the jaws of the clamp to close together upon any article which may have been placed between them when in a free position. On the rear end of clamp-rod 3 is secured a collar, 7, adjustable longitudinally thereon.

A driving-pulley, 8, is secured to casing 2 by a set-screw, in the usual manner. Said pulley is counterbored in one end, as shown, forming a chamber therein for the reception of a spiral spring, 9, and a flanged collar, 10, fits into the counterbored end of said pulley and bears against said spring 9. A longitudinal slot is cut in said pulley, as shown in Figs. 1, 2, 3, and a pin fixed in collar 10 projects into said slot in the pulley, thus adapting said pulley and collar to revolve together, but allowing a certain degree of longitudinal motion to said collar, to enter and recede from the chamber in the pulley in which is located said spiral spring 9.

When spindle B, together with the pulley 8, collar 10, and spring 9, is placed in its bearings *c*, the parts are in the position shown in the several figures, and collar 10 bears against the inner end of the bearing *c* adjoining it, spring 9 operating to crowd the pulley and spindle backward against screw *g*, which is adjusted to fix the open end of the screw-clamp 5 at the proper distance from the end of the cutting-tool *i*, and when such adjustment is made pulley 8 is set sufficiently far away from collar 10 to allow of a movement of the former toward the latter when the machine is operated, for the purpose hereinafter stated.

Spring 6 inside of casing 2 has a stronger expansive power than has spring 9 between pulley 8 and collar 10, to the end that pulley

8 and all of the spindle parts may have a certain degree of longitudinal movement in bearings *c* without causing spring 6 to be compressed, and thereby loosen the hold of the spring-clamp upon the work it may hold, and furthermore to permit spring 9 to force all of the spindle parts back against screw *g*, but with insufficient force to thereby loosen said spring-clamp.

The operation of my machine is as follows, viz: The relative position of the open end of the spring-clamp 5 and the end of the cutting-tool are determined by the thickness of the pieces to be turned in the lathe, and the spindle is moved to the required position by turning screw *g*, which drives it forward, or allowing spring 9 to move it back by withdrawing said screw, after which pulley 8 is set as above described, and the piece is inserted in the spring-clamp after moving it out from casing 2, and held therein by allowing it to recede again into it, operated by lever H, as hereinafter described.

It will be observed that by drawing the free end of lever H toward the center of the lathe, carriage *d*, carrying the tool *i*, is moved at right angles to the axial line of the spindle B, and that the degree of the movement of the tool relative to that of the lever is, within certain limits, governed by the position of the pin *r* in the slot *s* relative to the pivot-point *f* of said lever, and also that when lever H is operated as above described lever P is swung upon its pivot *x* by the operation of pin *m* in lever H against the edge of the form-plate *t*, and that carriage D is thereby caused to slide longitudinally on bed A, carrying with it carriage *d* and the tool *i*, and said longitudinal movement of carriage D is caused to be more or less rapid relative to the movement of lever H, according to the distance of pin *r'* from pivot *x*. Thus the single movement of lever H above mentioned imparts to the carriages D and *d* simultaneous longitudinal and transverse movements, which are of varying relative degrees of velocity, and which are determined by the relative positions of the movable pins *r* and *r'* in levers H and P.

When it is desired to turn the face of a disk or other similarly shaped piece so that the finish-line from its periphery toward its center shall curve outwardly, a curved form-plate, as shown, is used on lever P; but when a beveled edge is to be cut on said disk a form-plate having a straight edge running from point 12 to point 13 on plate *t* is used, making a plate of triangular form.

Bearing in mind the above explanations relative to the functions and operations of levers H and P, with their movable pins *r* and *r'*, in controlling the movements of carriages D and *d*, it will be seen that by changing the positions of said pins in said levers, so as to cause different degrees of transverse and longitudinal velocity to be imparted to the tool *i* as it cuts the piece being turned, curves or bevels of greatly varying pitch can be cut,

the curved or straight-edged form-plate being used for giving a general longitudinal movement to the tool, and specific forms of either curved or beveled shape are produced by changing the fulcrum-points of levers H and P on carriages D and *d*.

It will be understood that when pin *m* in lever P has moved beyond the curved or tapering edge of form-plate *t* onto a straight portion thereof it guides the tool to cut the central portion of the face of the disk flat, or nearly so.

By observing the positions of the movable pins *r* and *r'* in levers H and P when a certain curved or beveled form is cut, the same form may be reproduced at a future time by setting the said pins at the same graduation-marks as before.

The cut upon the work having been made as above described, lever H is moved back, causing its slotted arm, which engages with rod *o*, to slide the latter and draw arm *v* against collar 7 on the rear end of rod 3, causing the latter to slide forward, and by the resistance of spring 6 to carry spindle B, with the driving-pulley 8, with it, until the end of said pulley strikes the flange of collar 10, compressing spring 9, when the continued movement of rod *o* compresses spring 6 and causes the clamp-jaws 5 to slide forward beyond the end of the tubular casing 2, and, letting its jaws spring open, the turned piece drops out.

Should the form of a piece placed in the clamp-jaws 5 be such as to interfere with the proper contraction of them and prevent the latter from being drawn back by spring 6 far enough within casing 2, so as to hold the work at a proper distance from the end of the cutting-tool, thereby keeping the rear end of rod 3 from sliding back against screw *g*, then spring 9 within the chamber in pulley 8 operates, causing the whole spindle to move rearwardly against said screw, and to bring the work held by the jaws 5 into proper relative position before the tool, so that it may be cut of a proper thickness.

Lever *b* is adapted to be operated by a treadle to draw carriage D rearwardly on bed A, independent of the action of lever H, to draw tool *i* away from the end of spindle B for any required purpose.

The end of screw *e* is caused to bear against the bed A by the action of spring E, and by turning said screw the point of tool *i* is adjusted at a proper distance from its work to begin its cut, and said spring holds the edge of the form-plate *t* firmly against pin *m* in lever H when the parts are in operation.

What I claim as my invention is—

1. In combination, the carriage D, adapted to slide longitudinally on bed A, the carriage *d*, carrying the cutting-tool *i* and adapted to slide transversely on carriage D, and the mechanism, substantially as described and shown, for moving said carriages simultaneously by a single operating-lever, to cause the cutting-tool *i* to move toward the axial line of the spindle, and at the same time to recede from the end thereof, substantially as and for the purpose set forth.

2. The combination, with the carriage D, adapted to slide on bed A, and the carriage *d*, adapted to slide transversely on the first-named carriage, of lever H, pivoted on said bed and provided with a fixed pin, *m*, and a movable pin, *r*, adapted to engage with carriage *d*, and of lever P, pivoted on said bed and provided with a form-plate, *t*, and with a movable pin, *r'*, adapted to engage with carriage D, substantially as and for the purpose set forth.

3. The combination, with the carriages D and *d*, of the lever P, pivoted to bed A and provided with a form-plate, substantially as shown, of lever H, pivoted to bed A and provided with a fixed pin, *m*, and of the movable pins *r* and *r'*, located in said levers and adapted to be adjusted to co-operate with said form-plate, substantially as and for the purpose set forth.

4. The combination, with the elbow-lever H, its short arm, provided with a slot, as shown, of the sliding rod *o*, adapted to engage with said lever, arm *v*, and spindle B, substantially as and for the purpose described.

5. In combination with the tubular casing 2, the clamp-rod 3, spring 6, clamp-jaws 5, collar 10, spring 9, and pulley 8, substantially as and for the purpose set forth.

6. The combination, with spindle B, of pulley 8, provided with an annular chamber, as shown, spring 9, collar 10, the bearing *c*, support K, and screw *g*, substantially as and for the purpose set forth.

7. The combination, with spindle B, provided with the clamp-jaws 5, constructed and adapted to operate substantially as described and shown, of rod *o*, provided with arm *v*, lever H, provided with pin *m*, carriage *d*, adapted to carry tool *i*, carriage D, spring E, lever P, form-plate *t*, and the fulcrum-pins *r* and *r'*, substantially as and for the purpose set forth.

FRANCIS W. CLOUGH.

In presence of—

CHAS. BILL,

WM. H. CHAPIN.